



# Gorilla

## T-3815T

Introducing the New Gorilla T-3815T Heavy Duty Tracked Trommel



## Key Features

- 2.2 CAT Turbo Engine
- Tracked Mounted (Wheeled version available)
- 1.5m x 3.8m Direct Drive Trommel Drum
- Full Drum Accessibility with Dual Side Doors
- Maintenance Friendly with central grease points
- Fast on site Setup Time – only 10 Minutes
- Variable speed feeder and drum
- Fully sealed feeder reducing spillage
- Stockpile height of 2.49m Fines / 2.60m Overs



## General Dimensions

- Transport Length – 10.80m
- Transport width – 2.20m
- Transport Height – 3.20m (Brush and brush protector can be removed to bring height down to 3.05m high)
- Weight – 9,500kgs
- Operational Length – 12.40m
- Operational width – 2.20m
- Operational Height – 3.20m
- Weight – 9,500kgs



## Machine Arrangement

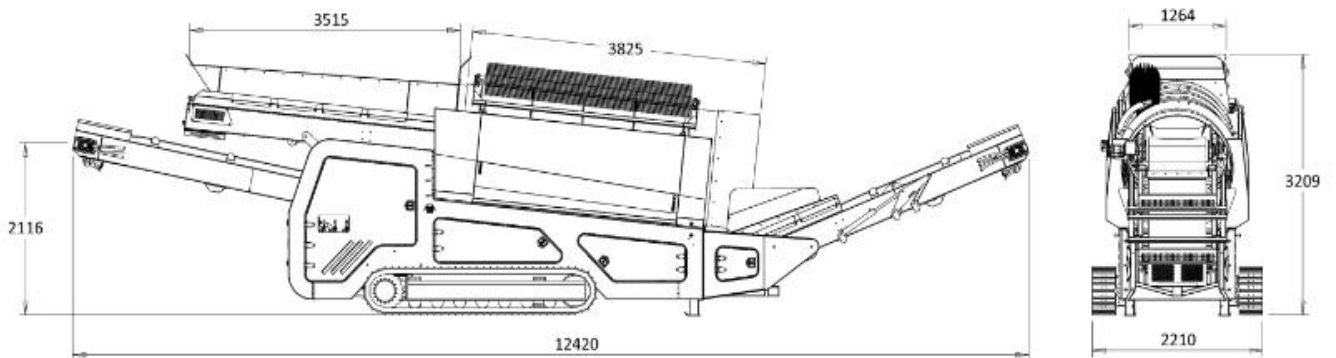

## Capacities

- Hopper: 2.5 Cubic Metres (3.2 Cubic Yards)
- Fuel Tank : 70Litres
- Hydraulic Fuel Tank Capacity : 265 Litres



## Engine

- C2.2 Caterpillar Turbo
- Engine Power: 60-61 BHP (44.7 – 45.5 BKW)
- RPM : 2800 – 3000
- Fuel Type : Diesel
- Fuel Consumption : 4ltrs / Hour



## Electronics (Basic)

- System Voltage : 12V
- Chassis Cabling : SWA Cable
- Emergency Stops : 2 (1 right and 1 left)
- Start Siren: Yes, (10 Second Delay)
- Engine Shutdowns : Low Oil Pressure, High temperature, Air filter blockage.

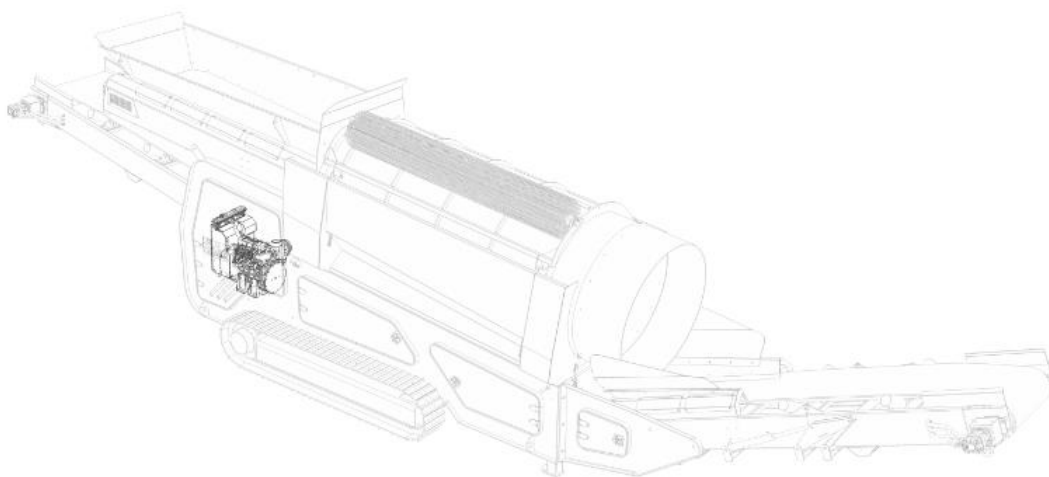

## FEED CONVEYOR

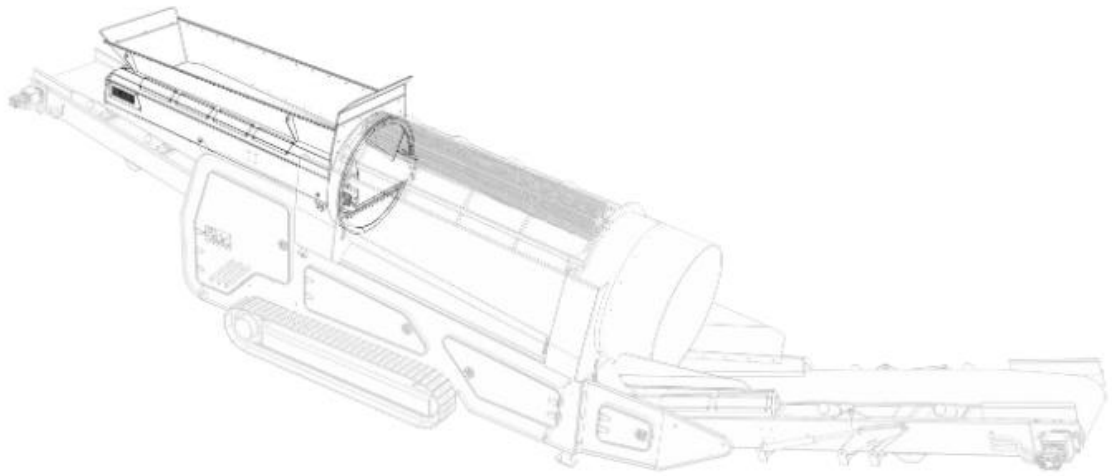

<b>Gearbox:</b>	Berma RT 160
<b>Gearbox Torque / Ratio:</b>	2000Nm cont. / 1:8
<b>Motor:</b>	OMP 315
<b>Belt Width / Length:</b>	1000mm (39") / 7.6m (24' 11")
<b>Belt Specification:</b>	4 Ply 5mm Top
<b>Drive Drum Diameter:</b>	280mm (11")
<b>Tail Drum Diameter:</b>	230mm (9")
<b>Maximum Speed:</b>	180 RPM
<b>Adjustable Speed:</b>	0-13 RPM

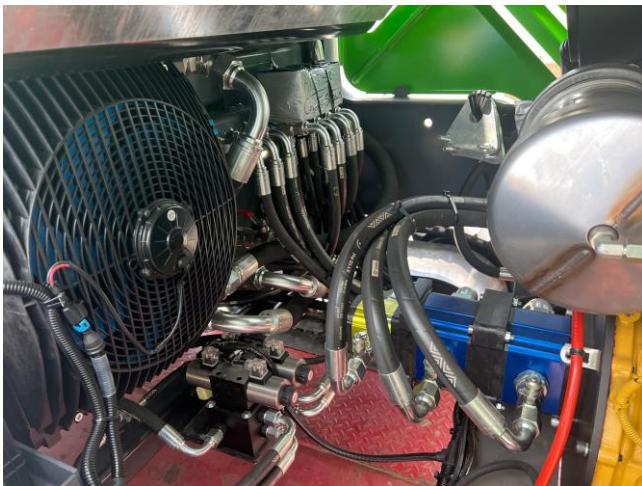

## FINES CONVEYOR

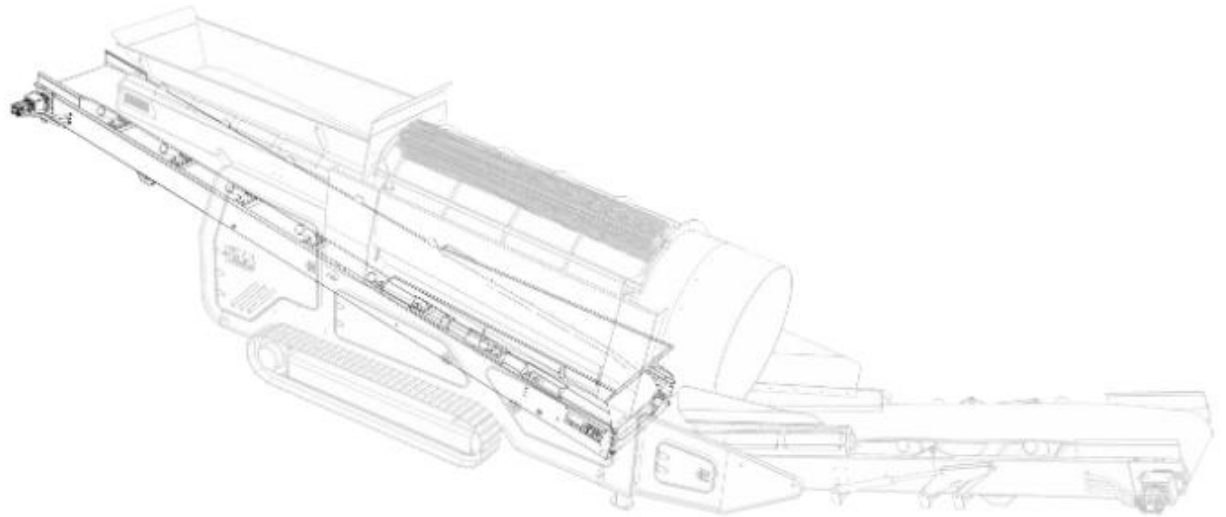

<b>Motor:</b>	OMT 400
<b>Belt Width / Length:</b>	900mm (36") / 16.0m (52' 8")
<b>Belt Specification:</b>	3 Ply 5mm Top
<b>Drive Drum Diameter:</b>	280mm (11")
<b>Tail Drum Diameter:</b>	230mm (9")
<b>Maximum Speed:</b>	180 RPM



## STOCKPILE CONVEYOR

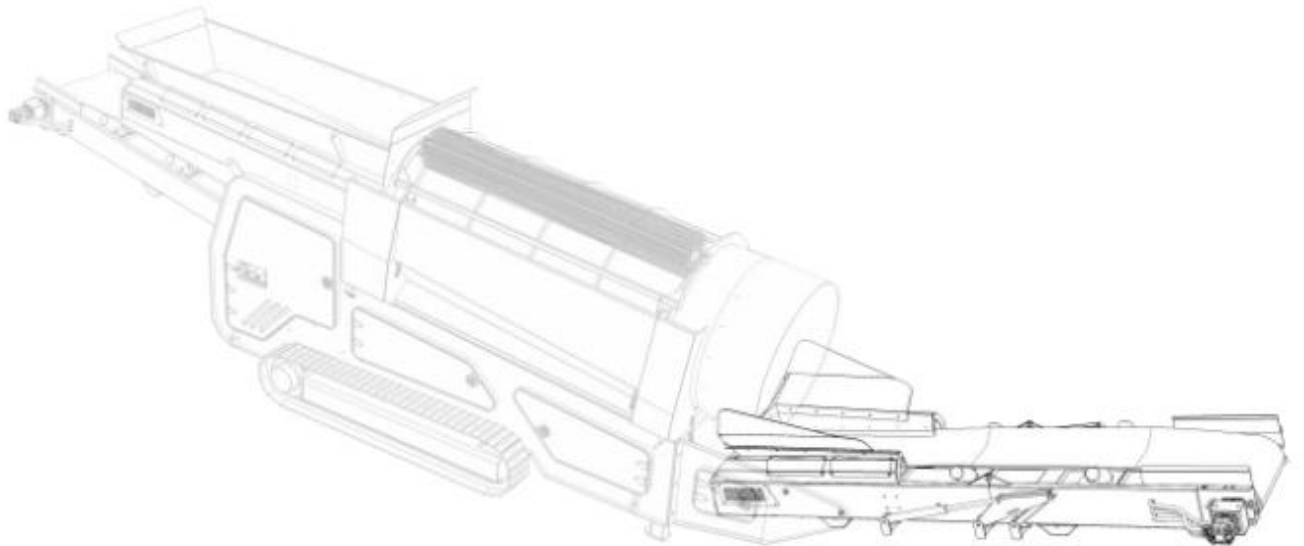

<b>Motor:</b>	OMT 400
<b>Belt Width / Length:</b>	750mm (30") / 8.5m (27' 10")
<b>Belt Specification:</b>	3 Ply 5mm Top
<b>Drive Drum Diameter:</b>	280mm (11")
<b>Tail Drum Diameter:</b>	230mm (9")
<b>Maximum Speed:</b>	180 RPM

## SCREEN DRUM

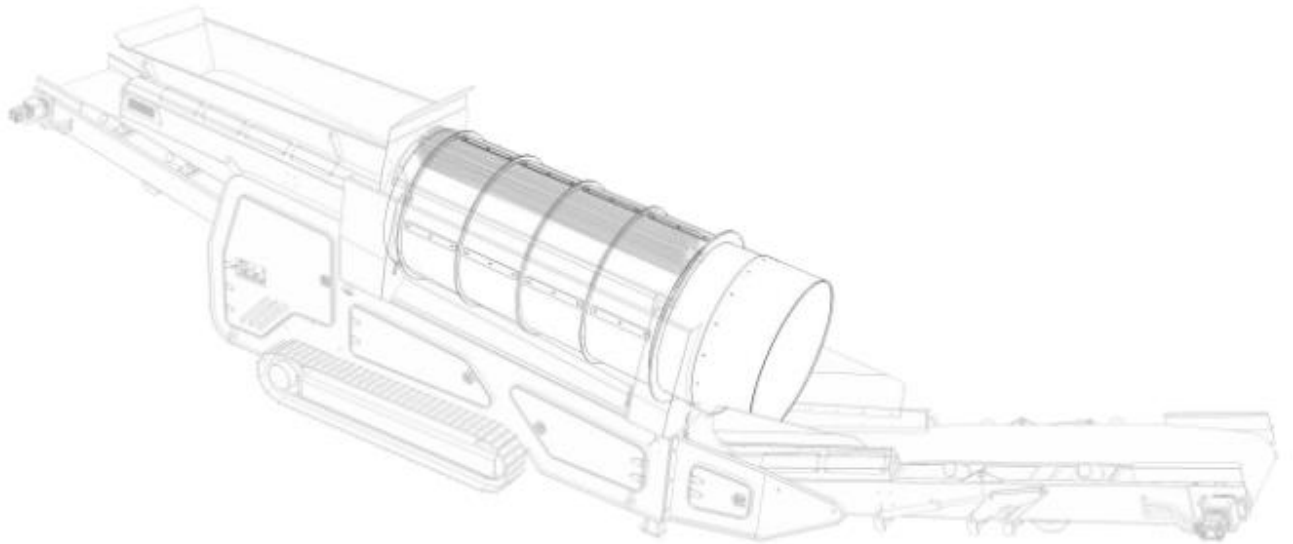

<b>Screen Diameter:</b>	1.5m (59")
<b>Screen Length:</b>	3.8m (12' 10")
<b>Motor:</b>	OMT 500
<b>Wheels:</b>	Solid 330 x 110 x 05 Stud

